

Verification of kinematic equations for a five-axis, table tilting machine tool

Julija Maletić

LOLA Institute
Belgrade, Serbia
julija.maletic@li.rs

Saša Živanović

University of Belgrade, Faculty of Mechanical Engineering
Belgrade, Serbia
szivanovic@mas.bg.ac.rs

Abstract— This paper analyzes a kinematic structure of a five-axis machine tool to obtain the equations needed for generating a postprocessor for this type of machine. The proposed machine is defined by a serial structure with two rotary axes on the machine table. The derived equations transform the CL data obtained by CAD/CAM software into a G-code that can be implemented on a machine. The analyzed equations were implemented in a postprocessing program using the Matlab software. The calculated data was used to verify the movement of the machine axes in a virtual surrounding.

Keywords—postprocessor; inverse kinematics; verification; simulation; virtual machine tools

I. INTRODUCTION

Multi-axis machining, by definition, is manufacturing that utilizes at least four axes of a machine simultaneously. With the use of multi-axis machines in the machining of complex, free-form surfaces, arises the problem of programming such machines. The solution to this problem comes in the form of using a CAD/CAM program in which it is possible to get to the desired program based on the model that needs to be manufactured. The final step during the making of the manufacturing program using a CAM system is postprocessing, in which a final program used on the machine is obtained. Typically, while using a CAM program, the geometry of the modeled workpiece is transformed into a CL file. In this file, the manufacturing of the desired workpiece geometry is defined as the CL data, which defines the position of the tool tip and the tool's direction. The case with this type of file is that it is universal and cannot be used directly on a machine. A *postprocessor* is a program that transforms the CL data into the specific motions of the machine's components with respect to the kinematic structure of the machine.

The mathematical model that transforms the CL data into the required movements of the machine axes is implemented in the postprocessor software. These types of equations are called inverse kinematic equations.

This paper presents part of the research done in, which is based on the research of Lee and She [2]. Lee and She propose defining the inverse kinematic for three typical types of five-axis machines. It is considered that all five-axis machines can be categorized into three groups based on the alignment of the rotation axes. This type of categorization includes multi-axis

machines with three orthogonal translation axes and two rotary axes. The first group are the machines with two rotational axes on the machine table, and the second group consists of machines with two rotational axes on the spindle. Finally, the third group comprises machines with one rotational axis on the table and one on the spindle. In another paper, She and Chang propose a postprocessor based on a generalized model of a machine tool [3]. The generalized model implies the existence of four rotational axes, two of which are on the table and the other two on the spindle. Different configurations of five-axis machines can be obtained by choosing the different rotational axes. Using a similar method, an inverse kinematics model can be derived for multi-axis machine tools with non-orthogonal rotary axes, as shown by Li, Liu, Fan, Fu and Wang in [4].

This paper represents the verification of kinematic equations used for postprocessing data for a five-axis table tilting machine tool based on [2]. Firstly, the method of derivation of the necessary inverse kinematic equations is displayed. The model of the machine on which the verification was carried out is subsequently shown. Ultimately, the verification process, which was done using two different software, is presented.

II. KINEMATIC EQUATIONS FOR FIVE-AXIS, TABLE TILTING MACHINE TOOL

The mathematical model used for describing the movements of the machine's components is based on defining the relative position between them. The complex transformation of coordinate systems can be obtained by first defining the simple translation and rotary movements using elementary transformation matrixes and then multiplying them in the correct order defined by the mechanism. The elementary transformation matrices are displayed in the (1)-(4) [2].

$$\text{Trans}(a, b, c) = \begin{bmatrix} 1 & 0 & 0 & a \\ 0 & 1 & 0 & b \\ 0 & 0 & 1 & c \\ 0 & 0 & 0 & 1 \end{bmatrix} \quad (1)$$

$$\text{Rot}(x, \theta) = \begin{bmatrix} 1 & 0 & 0 & 0 \\ 0 & c\theta & -s\theta & 0 \\ 0 & s\theta & c\theta & 0 \\ 0 & 0 & 0 & 1 \end{bmatrix} \quad (2)$$

$$\text{Rot}(y, \theta) = \begin{bmatrix} c\theta & 0 & s\theta & 0 \\ 0 & 1 & 0 & 0 \\ -s\theta & 0 & c\theta & 0 \\ 0 & 0 & 0 & 1 \end{bmatrix} \quad (3)$$

$$\text{Rot}(z, \theta) = \begin{bmatrix} c\theta & -s\theta & 0 & 0 \\ s\theta & c\theta & 0 & 0 \\ 0 & 0 & 1 & 0 \\ 0 & 0 & 0 & 1 \end{bmatrix} \quad (4)$$

In (1)-(4) $\text{Trans}(a, b, c)$ represents the translation along the vector $a\mathbf{i} + b\mathbf{j} + c\mathbf{k}$, whereas $\text{Rot}(x, \theta)$, $\text{Rot}(y, \theta)$, and $\text{Rot}(z, \theta)$ define the rotary movements of θ around the x, y and z axes, respectively.

As previously stated, the machine analyzed in this paper is a five-axis table tilting machine, which means that the mechanism has two rotary axes on the table. The rotary axes of the mechanism define rotary motions around the translation axes X and Z and are therefore designated by the characters A and C as shown in Fig.1. The purpose of the kinematic equations implemented in the postprocessor is to define the relative movements of the machine's translation and rotation axes as a function of the relative cutting tool position and orientation. The cutting tool position and orientation are defined regarding the workpiece coordinate system.

Fig.1. shows the workpiece and the cutting tool of the machine with the coordinate systems needed to define their relative positions. The analysis is simplified by defining an intersection point of the rotary axes, known as the pivot point (R). The pivot point's position is defined by the vector $[L_x \ L_y \ L_z]$. The workpiece and tool point are defined by the coordinate systems $O_w X_w Y_w Z_w$ and $O_t X_t Y_t Z_t$, where the vectors $[K_x \ K_y \ K_z]$ and $[Q_x \ Q_y \ Q_z]$ define the tool's orientation and position, respectively.

The following equations, known as the form-shaping function [2], define the transformation of relative tool position and orientation into the machine components' required translation and rotation movements:

$$\begin{aligned} [K_x, K_y, K_z, 0]^T &= \text{Trans}(L_x, L_y, L_z) \cdot \text{Rot}(z, -\phi_C) \cdot \\ &\text{Rot}(x, -\phi_A) \cdot \text{Trans}(P_x, P_y, P_z) \cdot [0 \ 0 \ 1 \ 0]^T, \end{aligned} \quad (5)$$

$$\begin{aligned} [Q_x, Q_y, Q_z, 1]^T &= \text{Trans}(L_x, L_y, L_z) \cdot \text{Rot}(z, -\phi_C) \cdot \\ &\text{Rot}(x, -\phi_A) \cdot \text{Trans}(P_x, P_y, P_z) \cdot [0 \ 0 \ 0 \ 1]^T \end{aligned} \quad (6)$$

$$[X \ Y \ Z \ 1]^T = [L_x + P_x \ L_y + P_y \ L_z + P_z \ 1]^T \quad (7)$$

where X, Y, and Z are the movements of the translation axes of the machine, $-\phi_C$ and $-\phi_A$ are the required angles of the rotational axes, and P_x , P_y , and P_z are the corrections of the X, Y and Z axes. Equations (5) and (6) are transformed into two vector equations, (8) and (9), by multiplying the elementary transformational matrixes and the corresponding vectors.

$$\begin{bmatrix} K_x \\ K_y \\ K_z \\ 0 \end{bmatrix} = \begin{bmatrix} s(\phi_C) \cdot s(\phi_A) \\ c(\phi_C) \cdot s(\phi_A) \\ c(\phi_A) \\ 0 \end{bmatrix} \quad (8)$$

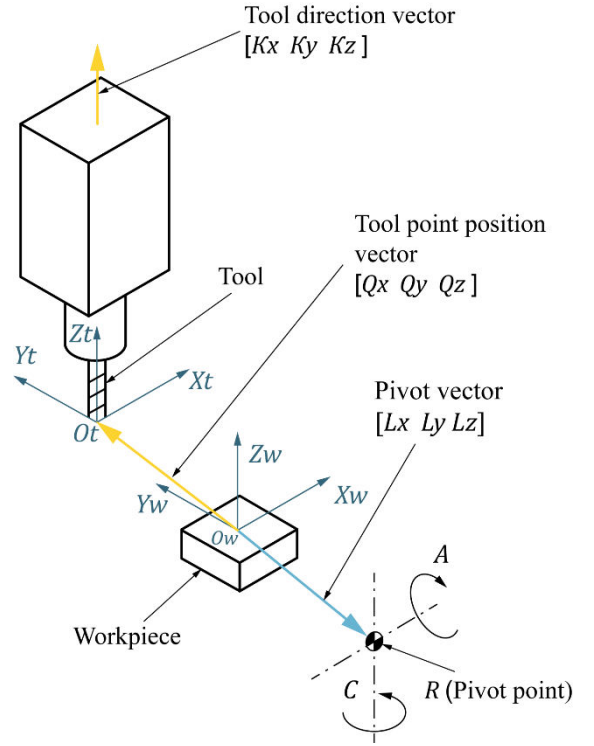

Figure 1. The vectors and coordinate systems of a table tilting machine [2]

$$\begin{bmatrix} Q_x \\ Q_y \\ Q_z \\ 1 \end{bmatrix} = \begin{bmatrix} c(\phi_C) \cdot P_x + s(\phi_C) \cdot c(\phi_A) \cdot P_y + s(\phi_C) \cdot s(\phi_A) \cdot P_z + L_x \\ s(-\phi_C) \cdot P_x + c(\phi_C) \cdot c(\phi_A) \cdot P_y + c(\phi_C) \cdot s(\phi_A) \cdot P_z + L_y \\ s(-\phi_A) \cdot P_y + c(-\phi_A) \cdot P_z + L_z \\ 1 \end{bmatrix} \quad (9)$$

The rotation angles are obtained using (4), which can be transformed into the following:

$$\phi_C = C = \text{atan2}(K_x, K_y) \quad (-\pi \leq \phi_C \leq \pi), \quad (10)$$

$$\phi_A = A = \arccos(K_z) \quad (0 \leq \phi_A \leq \pi), \quad (11)$$

where $\text{atan2}(x, y)$ is a function that returns the arctangent of x and y, with regards to the sign of both x and y. The final equations for the required movement of the translation axes, using (6) and (7), are defined as [2]:

$$X = L_x + P_x = L_x + c(\phi_C) \cdot (Q_x - L_x) - s(\phi_C) \cdot (Q_y - L_y), \quad (12)$$

$$\begin{aligned} Y = L_y + P_y = L_y + s(\phi_C) \cdot c(\phi_A) \cdot (Q_x - L_x) + c(\phi_C) \cdot c(\phi_A) \cdot (Q_y - L_y) \\ - s(\phi_A) \cdot (Q_z - L_z), \end{aligned} \quad (13)$$

$$\begin{aligned} Z = L_z + P_z = L_z + s(\phi_C) \cdot s(\phi_A) \cdot (Q_x - L_x) + c(\phi_C) \cdot s(\phi_A) \cdot \\ (Q_y - L_y) + c(\phi_A) \cdot (Q_z - L_z). \end{aligned} \quad (14)$$

These equations are then implemented in the Matlab software, and used for the necessary calculations.

III. CONFIGURING THE VIRTUAL MODEL OF THE FIVE-AXIS MACHINE

Equations (6)-(10) were tested on a CAD model of a five-axis table tilting machine. The chosen structural configuration of the analyzed mechanism is WC'A'X'VYZT, which means that the workpiece can be moved using the X, A, and C axes. At the same time, the movement of the tool is defined in the Y and Z directions of the machines' coordinate system. A simple kinematic structure of the analyzed machine is shown in Fig.2a.

A simplified machine model was made using the PTC Creo Parametrics software. Only the necessary parts of the machine that define the machine's axes' movements were used to simplify creating the machine's virtual model. The virtual model used for verifying the inverse kinematic equations is shown in Fig.2b. In order to verify that the virtual machine was correctly configured, a manufacturing simulation was run using the machines' assembly.

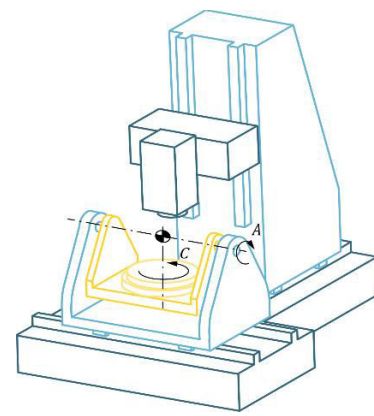
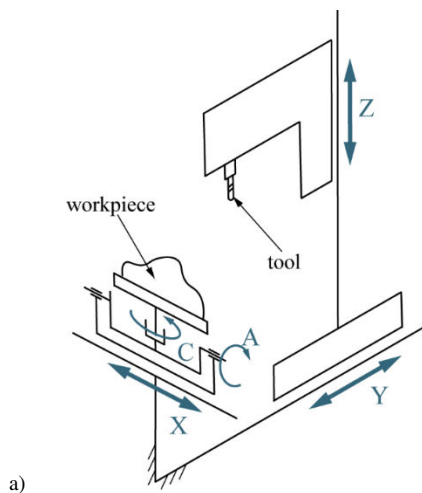

Figure 2. The model and the CAD assembly of the analyzed machine

As previously stated, the CL data in this kinematic model is defined by the vectors $[K_x K_y K_z]$ and $[Q_x Q_y Q_z]$. Aside from that, the necessary parameters of the mechanism need to be defined. In this case, that is the distance between the pivot point and the workpiece coordinate system. The output data defines the necessary movements of the machine's components, in this case, the movements of the X, Y, Z, A, and C axes. The verification was done in two different programs, PTC Creo Parametric and Vericut. As previously stated, the CL data is generated regarding the workpiece coordinate system, which is, in this case, located in the center of the top surface of the cube-shaped workpiece.

IV. VERIFICATION OF THE INVERSE KINEMATIC EQUATIONS ON VIRTUAL MACHINE TOOLS

To verify the inverse kinematic of the machine (10)-(14) were implemented into the Matlab software. For this program, input data represents the CL data, the position and orientation of the tool in regard to the workpiece coordinate system.



A. Verification in PTC Creo software

In the first verification, the machine's movements were implemented in the machine's assembly by adjusting the parameters of the kinematic connections. In this case, the kinematic equations were tested for three different sets of CL data. The first test required translation movements of the tool without changing its orientation, whereas the second and the third experiment required the rotation of the A and C axis, respectively. In the second experiment, the angle of the rotational axis A was specified at 45 degrees, while in the third test, the desired rotary angle of the axis A was kept at 45 degrees, and the C axis angle was changed to 90 degrees. In order to do the tests, the models of the tool and workpiece were added to the machine assembly. For all three tests, the tool point was positioned in the top right corner of the workpiece. The verification will be considered successful if the tool position and orientation required at the beginning of the test are the same as the position and orientation of the tool realized in the assembly. The results of the tests are presented in Table 1.

Fig.3 shows the results of the previously mentioned tests. The results of the translation test displayed in Fig.3a show that the test was successful because of the correct positioning of the tool. Figs. 3b and 3c exhibit the results of rotation angle equation tests, where it is shown that in both cases, the achieved angles of the A and C are the same as the ones defined at the beginning of the test.

TABLE I. INPUT AND OUTPUT DATA FOR THE POSTPROCESSOR

	First test	Second test	Third test
--	------------	-------------	------------

Input (CL) data	KX	0	0	0.7071
	KY	0	0.7071	0
	KZ	1	0.7071	0.7071
	QX	50	50	50
	QY	50	50	50
	QZ	0	0	0

Output (G code) data	A	0	45	45
	C	0	0	90
	X	50	50	-50
	Y	50	155.5635	155.563
	Z	0	85.1472	-84.852

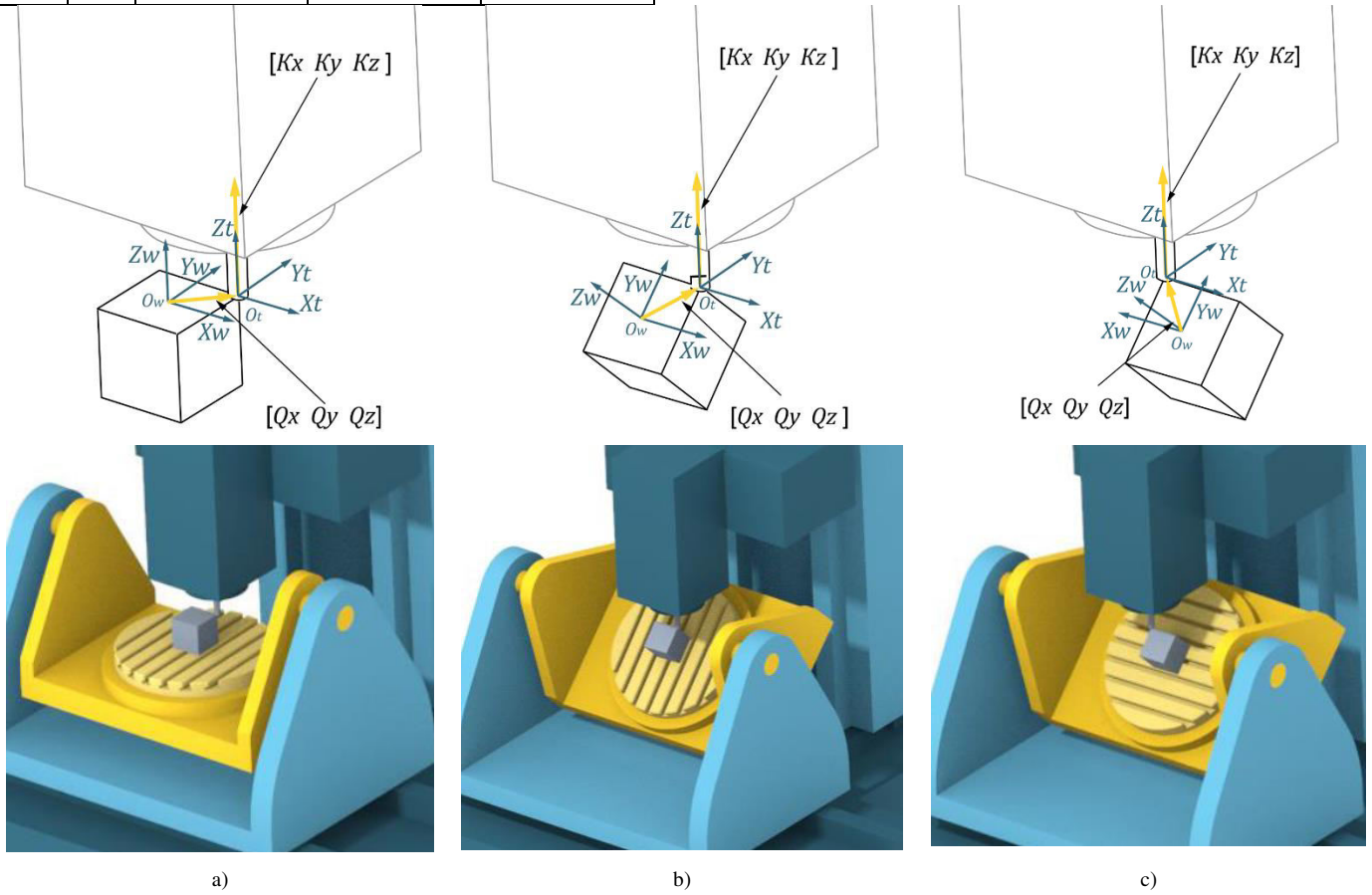

Figure 3. The model and the CAD assembly of the analyzed machine

B. Verification in Vericut software

The inverse kinematic equations were verified for the second time in the Vericut software. This software enables the machine, tool, and workpiece to be defined in a material removal simulation, based on a G code [1,5]. While configuring the machine assembly, the movements of the machine parts are defined in the correct direction of the machine's coordinate system. In order to do that, the machine's virtual model in this software must be configured according to the machine's kinematic structure (WC'A'X'VYZT).

The configuration process starts with the machine's base, implemented as a fixed component in the Vericut software. Next, the components defining the tools and workpiece movements are added in two groups. The first group defines the movements of the workpiece, and the second group is made up of components that enable the movements of the tool. The first group consists of the X, A, and C axes added to the stationary base in that order. Given that the rotation of the C

axis directly affects the workpiece, an attachment is added after it to define the workpiece's model (Stock). In order to complete the virtual model, the second group, consisting of the Y and Z axes were added to the machine's base. All of the components must be defined regarding the pivot point to accomplish the correct movements of the rotary axes. In this simplified model, the tool is directly added to the component defining the Z movement, representing the machine's spindle. The abovementioned process of configuring the virtual model of the machine can be seen in Fig. 4, where the hierarchical tree structure of the machine is shown.

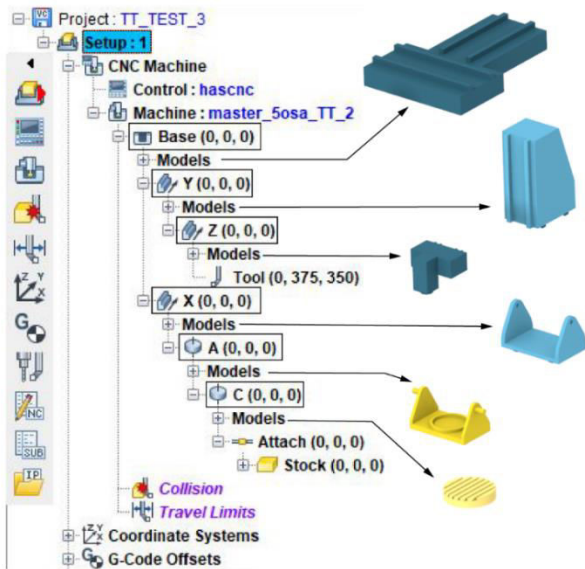
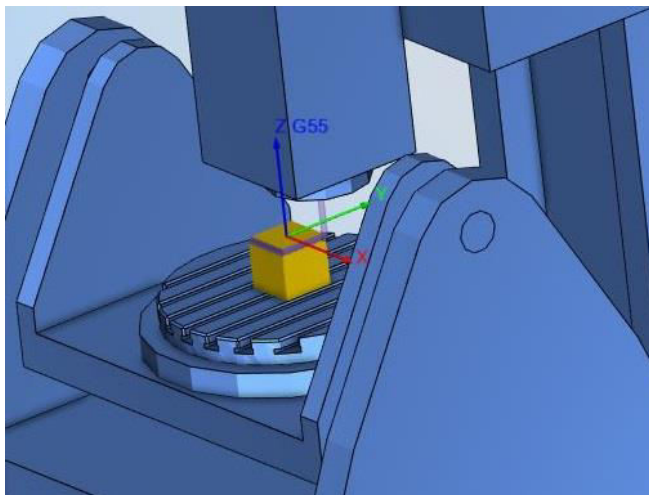
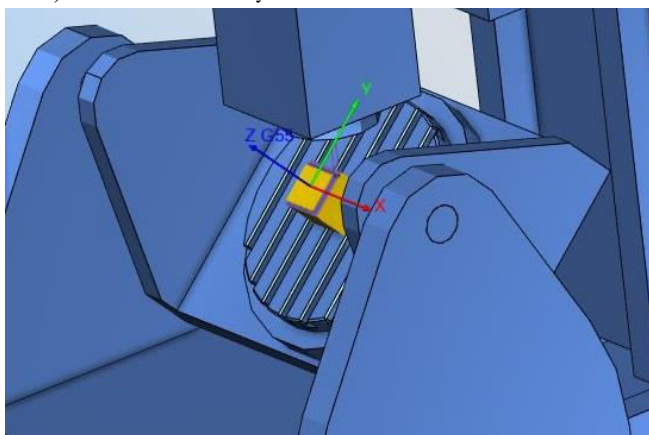

Figure 4. Hierarchical tree structure of a table tilting machine



a) Orientation of rotary axes A0 C0



b) Orientation of rotary axes A45 C0

Figure 5. The results of the Vericut verification

This software can simulate material removal based on G code or CL file during the manufacturing process. The G code was generated based on the data collected using the Matlab inverse kinematic program for the purpose of simulating the manufacturing process within Vericut software. Fig. 5 represents the key points of the abovementioned simulation.

Within this simulation, the tool was first moved along the upper surface of the workpiece without using rotary axes (A0 C0) and then used rotation A45 C0 for edge milling to verify the positioning of the rotating axis. In this way, the considered postprocessor was tested on a simple example, with the aim of further implementation in the software environment for postprocessing of complete G-code for machining a complex surface.

This software environment is very suitable for postprocessor validation because it has the ability to execute G-code, as well as the ability of virtual machine configuration, with a proper control system.

V. CONCLUSION

Modern manufacturing of complex free-form surfaces requires the use of multi-axis machine tools. The choice of a postprocessor, and the equations it is based on, significantly impacts the performance of these machines.

This paper presented a method of developing and testing an inverse kinematic model for a five-axis table tilting machine. The inverse kinematic model represents the necessary equations used in a postprocessing program which transforms the CL data into a G code. The following steps would be generating a postprocessor based on the equations derived in this paper, which would automatically transform the required data.

This paper also demonstrates the importance of testing any new program on a virtual model of a machine before implementing it on a real-life machine. This approach aids in shortening the time needed between the manufacturing of different parts. Testing a new G code on a virtual machine model also helps eliminate the errors in the program before the manufacturing -process, thus reducing errors.

ACKNOWLEDGMENT

The presented research was supported by the Ministry of Education, Science and Technological Development of the Republic of Serbia by contract no. 451-03-9/2021-14/200105 dated 5 February 2021 and by contract 451-03-9/2021-14/200066 dated 28 January 2021.

REFERENCES

- [1] J. Maletić, "The verification of postprocessors for multi-axes machine tools" (Verifikacija postprocesorskog računa za višeosne mašine alatke), Master's degree final project, University of Blegrade, Faculty of mechanical engineering, 2021.
- [2] R.-S. Lee and C.-H. She, "Developing a postprocessor for three types of five-axis machine tools", *International Journal of Advanced Manufacturing Technology* 13, pp. 658–665, 1997.
- [3] C.-H . She, and C.-C. Chang, "Design of a generic five-axis postprocessor based on generalized kinematics model of machine tool",

- International Journal of Machine Tools and Manufacture, 47(3-4), pp. 537-545, 2007.
- [4] T. G. Li, D. M. Liu, Z. G. Fan, C. L. Fu, and W. S. Wang, "Design of a Generic Postprocessor Based on UG", Advanced Materials Research, vols. 335-336, pp 625-628, 2011
- [5] N. Vokapic, S. Zivanovic, Z. Dimic, B. Kokotovic, N., Slavkovic, "Virtual Horizontal Machining Center LOLA HBG 80 for Program Verification and Monitoring", FME Transactions, vol. 49, no. 3, pp. 696-703, 2021.