

Light Weight Robot Arms – An overview

Svemir Popić, Branko Miloradović
 Center of Robotics
 Mihajlo Pupin Institute, Volgina 15
 11060 Belgrade, Serbia
 (e-mail: svemir.popic@pupin.rs).
 (e-mail: branko.miloradovic@pupin.rs).

Abstract— Industrial robot – manipulator is an irreplaceable device capable to execute the task of accurate and repeatable positioning of its end effector. In order to achieve this goal system rigidity is very important as well as installed power, capable for fast and reliable manipulation of both: its own weight and payload. Light weight arms, on the other hand, have very complex task. Ratio between self-mass and payload must be as low as possible along with limited power consumption and satisfied system dynamics. This is accomplished with new design solutions, new mathematical approaches as well as with new control systems.

Keywords-component; Lightweight arms, system rigidity, compliance

I. INTRODUCTION

Light weight arms are, by the definition, robots with small own weight, especially dedicated for tasks execution in places where its adaptability is required as well as the certain operation in an unstructured environment. Thereby also thought the existence of direct contact with humans. In order to achieve this, they are required to be light, payload has to be proportional to its own weight, needs to be significantly fast almost like humans whose functions in some segments will take over. These velocities are reaching incredible 6m/s. In order to ensure capabilities of imitation and realization of skills and compliance of movements the modularity, the integrability of mechanical and electrical components, sensitivity and controllability are required. All of that are characteristics of so called Soft robotics [1].

Table I is a nice comparison between traditional industrial robotics and a new pursuits, e.g. new concepts of robotics in future [12].

As can be seen, the conception of such robots is in contradiction with today's industrial robots, whose mechanical design is primary focused on reliable fulfillment of their tasks. This means continuous, cyclical, reliable repetition of certain pre-programmed movements. It should be noted that in conventional industrial robots, relation of its own weight and payload is about 10:1, but in a reviewing data of different world robot producers can be found that this ratio can be much higher and it is depending on the type and the use of the robots. If one adds the loads that occur as a result of the proportionate dynamics, it is logical that such conception require high stiffness, and thus a proper weight. The control task can be relatively easy solved based on the classical elements and components of feedback. It must be noted that industrial robots operate exclusively in a structured environment. In contrast, imposed weight restrictions and close contact with humans, as well as prevention of possible injuries, have limited their installed power. In addition, their positions and the unknown (unstructured) environment have set constructors additional requirements. It is no longer enough to provide reliable accuracy and repeatability, but primarily adaptive conduction. This means that produced force should not hurt the persons that are in direct contact with, nor to undermine the integrity of its body, and objects in the robot surroundings. Such an approach has imposed a direct task to the robot control system i.e. to reliably measure and align its behavior with the measured forces and moments occurring in a contact with the environment. Currently, in a case of collision, the response of the system is achieved in 1 ms only.

TABLE I
 THE DIFFERENCE BETWEEN CLASSIC (INDUSTRIAL) ROBOTICS AND NEW ROBOT GENERATION

“Classical” Industrial Robot	New Generation Robot
Fixed installation	Flexibly relocatable (manually or on mobile robots)
Periodic, repeatable tasks; seldom changes	Frequent task changes; tasks seldom repeated
Programmed online / offline by a robot specialist	Instructed online by a process expert supported by offline methods
Infrequent interaction with the worker only during programming	Frequent interaction with the worker, even force/precision assistance
Worker and robot separated by fences	Workspace sharing with the worker
Profitable only with medium to large lot sizes	Profitable even with small lot sizes



Fig. 1. Barrett hand with Barrett wrist

Although it could be carried out by various divisions, almost all recognizable structures can be classified in two main groups. These are: lightweight modular robotic arms and robotic arms with the cable driving system. The both structure commonly have lightweight construction (structure), limited (low) installed (drive) power and a built-in compliance. With a use of modern materials, primarily carbon and glass fiber composites, light alloys based on aluminum and titanium, the mass of the moving parts – segments is reduced, the inertia is decreased, and as a consequence it resulted in the restriction of the driving forces in less than 80 W. The result of that is creation of safer environment for interactive human-machine operation. This led to numerous advantages as: the smaller masses of moving parts, easier to operate, easier to stop in case of possible collision, which all led to safer working environment.

The new technologies have led to the miniaturization of components so that it is enabled by integrability of complete drive train (engine, gearbox, sensors, and even the associated electronics) in one unit, which now can be allocated even in some robotic joints and in same fingers of robotized artificial hands. Although these are very expensive components, which price increases with miniaturization to unimaginable "sizes", the big problems of power transfer from the remote drive has been avoided, regardless of the method of achieving this transfer.



Fig. 2. DLR – KUKA Lightweight robot

The new concept of power [2] does not require anymore high speeds i.e. the high revolution per minute, but on the other hand it requires a large torque at medium speeds. The low energy losses and high dynamics are intended and exclusively designed for this purposes.

Harmonic Drive reducers with the improved load / weight ratio are miniaturized to unimagined proportions. The control system now, in addition, is responsible to measure directly position and torques in the wrist, with the aim of providing compliance and smooth operation - movement.

On the other hand, light weight robots with wire actuation (tendon-based) are characterized by the following features:

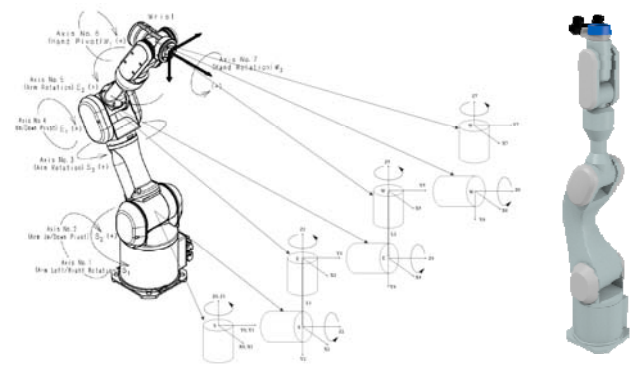

Fig. 3. Mitsubishi P 10 Light weight robot

- Actuators are relocated outside of the joints (or their closer surrounding – e.g. palm) and therefore the weight of the moving parts is reduced,
- Parts that are triggered by wires - cables are routed through the shells or transferred through a system of pulleys,
- In order to ensure the mechanical reversed movement in the situations of the eventual collision (back-drivability), the reduction ratio is decreased. In fact these are the speeds (forces) that arise as a result of moving (executive) parts of actuators (pneumatic cylinders, artificial muscles, linear actuators...)

As a result of providing such claims price has been paid with the following limitations:

- In comparison with conventional industrial robots, the flexibility in the joints has been increased and that caused the more complex dynamics of the whole system, which now must be controlled with contemporary control techniques in order to ensure satisfactory performances of movements,
- Miniaturization of components in general, while meeting the defined performances, raised the price of these devices (light weight arms) and it is now, at an early stage of production, significantly higher than conventional industrial robots.



Fig. 4. Yaskawa – Motoman SIA5F.

In the world, at universities or at well-known robot manufacturers, can be recognized some of them, whose features, design, specifications or time of occurrence, can be described as successful. Stand out: Barrett arm – WAM (Fig. 1.) [3], DLR - KUKA (light weight arm) (Fig. 2.) [4], Mitsubishi PA10 (Fig. 3.) [5], Yaskawa – Motoman SIA5F (Fig. 4.) [6].

II. THE CONSTRUCTIVE ANALYSIS

What is it that a light robot differs from other robots? When we start with the robot design of such features in accordance with the set goals, we have to define the tasks, whose success of realization depends on resolving these concepts. In fact, many elements have to be constructed or the existing have to experience significant changes. We will mention just a few.



Fig. 5. Barrett 6-axis force / torque sensor is completely independent device that significantly improves the properties of WAM hands.

This sensor is made of high strength aluminum alloy for aerospace applications (Al 7075-T6) and titanium. It is very lightweight and sturdy, and integrated strain gauges are 75 times more sensitive than conventional foil strain and it weight is less than 10 grams and 20 times more durable than the assumed limit load [8].

In Fig. 6. the main characteristics of such force sensor are given.

Specification	Value	
Total Mass	136 g	
Dimensions	Diameter	90 mm
	Height	12 mm
Sensing Range	Fx, Fy	± 80 N
	Fz	± 135 N
	Tx, Ty	± 2.75 N-m
	Tz	± 2.75 N-m
Sensing Resolution	Fx, Fy	50 mN
	Fz	80 mN
	Tx, Ty	1.5 mN-m
	Tz	1.5 mN-m
Single-Axis Overload	Fx, Fy	3000 N
	Fz	3600 N
	Tx, Ty	60 N-m
	Tz	100 N-m
Input Voltage*	Typ	48 V
Power Requirement	Typ	1.7 W
Communication	Mode	CANbus
Output Resolution	Each axis	12 bits
Noise (without filtering)	Typ	2 bits
Update Rate	Max freq.	2.5 kHz
Hysteresis	Typ	<5%

Fig. 6. Barrett 6-axis force / torque sensor – technical characteristics

One of the ways to change existing and almost commonplace constructive solutions for robotic joints actuation is shown in the following figure (Fig. 7), where the torque transmission is accomplished by a highly improved system of steel cables that are coiled on or slide over a very hard ceramic surfaces, that are, in order to minimize of friction, coated with a layer of teflon. This transmission has some advantages over the classical solution with gears because it is very quiet, has a smoother running, greater rigidity and strength.

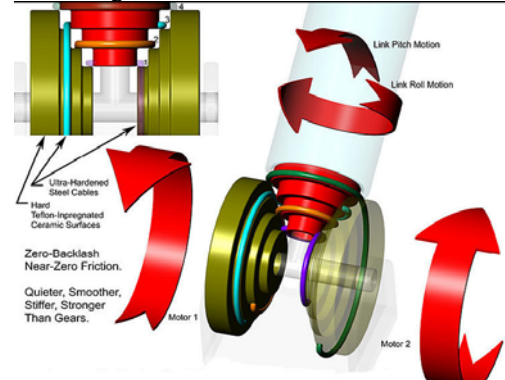

Fig. 7. Barrett arm (WAM) – drive system

The solution for cable pretension is patented. It practically nullifies the clearances and the task of advanced control system is to compensate the elasticity in the whole robotic system.

WAM arm is one of the few lightweight robot arm that is commercially available in two variants with 4 and 7 degrees of freedom (DOF). Some of the main characteristics are given in the table in Fig. 8.

WAM SPECIFICATIONS		
Power Requirement (AC Operation)	100-240 vac 1φ 50-60 Hz @ 60 watts minimum	
Mobile (DCN) Operation	24-80 vdc @ 50 watts minimum	
Reach	4-DOF	1000 mm
	7-DOF	1000 mm
Payload	4-DOF	4 kg
	7-DOF	3 kg
Endtip velocity	Max	3 m/s
Mass of robot	4-DOF	25 kg
	7-DOF	27 kg
Work volume	3.5 m ³	
Repeatability	4-DOF	1000 μm
	7-DOF	2000 μm
...with joint encoder option	4-DOF	100 μm
	7-DOF	200 μm
Mechanical Stiffness	1.5E6 N/m	
Control stiffness	5000 N/m	

Fig. 8. Barrett hand (WAM) – Some of the main technical characteristics

In Fig. 9. one different approach is illustrated, developed in famous DLR Institute in Germany, and then transferred to reputable manufacturer KUKA robots.

As you can see from the enclosed, all that is needed, the driving system and the electronic components have been housed and integrated into appropriate robot joint. Two versions of entire robot, LVR III with 6 degrees of freedom and LVR IV with 7 degrees of freedom have been developed.

A total of 18 prototypes LVR III have been created and after that, at Zero series, the new 60 pieces of LVR IV that were sold or outsourced to universities for further testing. To make this possible, practically all components are designed purposely under the following conditions:

- Maximum load capacity (payload),
- Minimum (own) weight,
- A central opening (hole) for the transfer of cables and pipes...

Links between the joints are based on carbon fibers. When everything is taken into account it is clear why this is the only robot that can carry as much as its own weight. Of course, all this comes at a price which is, above all, paid with increased elasticity and with reduced robot accuracy.

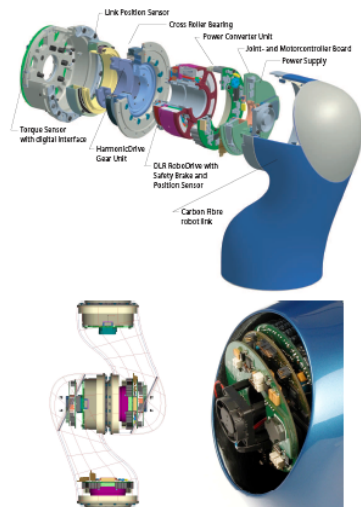

Fig. 9. DLR – KUKA LWR (light weight arm) – Expanded CAD model

The characteristic of these robots is modularity. The manufacturer has conceptualized solution based on just a few types of elements which can be assembled in a final form.



Fig. 10. DLR – KUKA – Modules for light weight arm assembly

This makes sense because it increases not only the productivity of robots, but also expands the range of application which means that the form can be modified according to the needs of users. There is a noticeable oval

contour in order to prevent any sharp contact with the environment [10].

Practically all the elements have experienced changes or were newly constructed. Such is the motor (RoboDrive) with associated performance tables shown in the following figure (Fig.11). Opening in the central part except for the transfer cable (only takes 5 cables) also reduces weight and inertia.



Performance characteristics

Motor size	Rated power (P)	Rated torque (M _{nom})	Peak torque (M _{max}) (20% linearity deviation)	Rated voltage (U _{nom})	Rotation speed @ U _{nom} (n)	Rated current (I _{nom})	Loss from stand stills @ U _{nom} (P _{standstill})	Thermal constant (phase current amplitude) (K _t)	Motor constant (K _v)	Terminal resistance (R) @ 20°C	Terminal inductance (L)	Rotor inertia (I)	Max. Efficiency (η)	Size of mounting kit (m)
	W	Nm	Nm	V	1/min	A	W	Nm/A	Nm/V	mΩ	μH	kgcm ²	%	g
25	60	0,024	0,10	24	24000	2,8	490	0,008	0,012	500	170	0,0023	85-1	16
38	125	0,10	0,35	24	12000	5,0	700	0,021	0,039	363	250	0,010	85-1	52
50	140	0,28	0,9	48	5500	3,5	950	0,075	0,088	552	720	0,049	86	86
50x14	145	0,46	1,4	48	3500	3,5	13,8	0,131	0,125	800	820	0,086	84	135
70	270	0,74	2,3	48	3500	7,0	17,5	0,106	0,177	470	800	0,21	90	230
70x18	370	1,25	4,0	48	2200	7,0	24,0	0,180	0,255	655	1350	0,34	90	340
85	490	1,43	4,5	48	3000	11,0	20,0	0,130	0,328	210	470	0,61	92	370
85x23	580	2,30	7,3	48	1900	11,0	30,0	0,210	0,426	320	890	0,98	92	550
115	735	5,40	18	48	1300	20,0	38,0	0,270	0,880	125	525	3,65	92	1200
115x50	880	11,2	40	48	650	20,0	65,0	0,560	1,410	240	1170	7,90	92	2170

Fig. 11. RoboDrive – The appearance and performance of a new generation of motors [11]

III. COMPARATIVE ANALYSIS

TABLE II
SOME CHARACTERISTICS OF SELECTED SYSTEM PERFORMANCES

	Barret arm	DLR – KUKA light weight arm	Mitsubishi PA 10	Yaskawa – Motoman SIA5F
Number of active axes - DoFs	4 or 7	6 (7)	6 or 7	7
Maximal payload [kg]	4 (3)	7 14 limit	10	5
Repeatability [mm]	1 (0.1)*	0.5	+/- 0.1	+/- 0.6
Working space [mm]	1000	935	950	559
Weight [kg]	25 (27)	14 (22.3)	40 (35)	30
Installed power [kW] minimum	0.06	0.150	1.5	1.0
Velocity [m/s]	3	2	1.55	200 ^{0/s}
Acceleration [m/s ²]	30 (20)	0.3 rad/s ²	0.7	/
*(on request)				

IV. EXAMPLES OF APPLICATION

Possessing these features, lightweight robots are imposed as a "drug of choice" in the examples where one compliant, safe and reliable system is required. It is for instance in cases for application of robots in rehabilitation or assembly. According to [7], DLR - Kuka robot LWR is ideal for such tasks. One example is given. In Germany, every year, about 200,000 people suffer some injuries, and even 30% of them have injuries that require the implementation of some of the procedures of physical rehabilitation. For such a large number of patients who need help there are not enough therapists. Because the certain repetitive procedures can, with an accompanying monitoring, assign to the light weight robots that now gets the task execution. Although in the literature could be found the examples of using the conventional industrial robots for such purposes, their use remains limited. This is primarily a matter of specific neurological features such as uncontrollable muscle spasms, where the classical robot could cause additional complications, while the lightweight robot according to their characteristics, i.e. built-in sensors of forces and torques in each of the joints, is very effective. Namely, while the classical industrial robot (but not each) had eventually incorporated some of the force/moment sensors in the executive device (for instance tool or gripper), in accordance with the nature of the task, the point is at each joint LWR robot equipped with such sensors, which enables to react in all cases where may occur the contact with the environment of any part of the robot body. With such a construction robot may practically simulate the spring with adjustable stiffness. In such cases of direct contact with humans, in order to avoid possible injuries, robot "includes" only the weight compensation and guides the patient through the exercise without the introduction of "over force" i.e. introduces only as much as necessary to follow up the corresponding motion trajectory. This can be expressed in another way. Lightweight robot in this way is open for acceptance of external forces and moments that "memorize" in its control system and reproduces in accordance with the user requirements.



Fig. 12. The Barrett hand (WAM) – application in rehabilitation [9]

V. CONCLUSION

There is a long way from idea to realization. Every day, with the big steps we are going forward. From the

first ideas in 1991 until now it has been more than 20 years. In this period the different systems have been realized and they all gave their contribution to a next-generation of robots. It should be noted the importance of the decision to assign the 18 prototypes of LWR III to the universities for testing and providing useful comments and improvements. The result is the commercialization of LWR IV, which not yet came into some mass application, but already is in designing processes the different experimental flexible cells like in the Mercedes Company for assembly of transmission. The modularity of the structure extends the application in the various areas of research from medicine to cosmology.

We should mention the fact that in the Robotics Laboratory at Mihailo Pupin Institute, several modular joints, types RMW and RMDW were designed. This was done for Canadian company named ESI in the late nineties. These joints were later incorporated in on SCARA robot. These joints were also modular with integrated motors (Kollmorgen), reducers (Harmonic Drive), encoders (Hewlett Packard HEDS 5500), electronics based on standard PC 104 card, all in one housing made from standard square aluminum tubes (Al 6061 T6) of 5 inches (127 mm). It is missing only the force sensor and new design form to create again something similar in the Mihailo Pupin Institute.

ACKNOWLEDGMENT

The paper was written under the auspices of the project TR-35003 III-44004 as well as III-44008 funded by the Ministry of Education and Science of the Republic of Serbia, and is partially supported by the international project under the symbol SNSF Care Robotics IP project IZ74Z0_137361 / 1 as well as bilateral Serbian - Portuguese research project with "Colbar" 451-03-02338 / 2012-14 / 12.

REFERENCES

- [1] Gerd Hirzinger and Alin Albu-Schaefer (2008), Scholarpedia, 3(4):3889.
- [2] http://www.tq-roup.com/fileadmin/web_data/tx_dataminstqproducts/downloads/tq_db_rob_torque-servomotor_en_102_Web_01.pdf
- [3] <http://www.robotnik.es/en/products/robotic-arms/barrett-wam>
- [4] http://robotssystem.ir/en/history/uploads/tx_ifrtimeline/KUKALtwRobot.jpg
- [5] <http://blog.azizian.ca/?cat=3>
- [6] <http://www.juneusa.com/index.php/robot-repair/motoman/>
- [7] www.tar-conference.eu/tar-conference.../session-2-event-1-bollue.pdf
- [8] www.barrett.com/robot/DS_FTSENSOR.pdf
- [9] www.barrett.com/robot/DS_WAM.pdf
- [10] www.dlr.de/rm/Portaldata/52/.../rm_status_report_2004_web.pdf
- [11] www.tq-group.com/.../tq_db_rob_torque-servomotor_en_102_Web_01
- [12] Rainer Bischoff; Johannes Kurth; Guenter Schreiber; Ralf Koeppe and more authors: The KUKA-DLR Lightweight Robot arm - a new reference platform for robotics research and manufacturing, *Robotics (ISR), Proc. of 41st International Symposium on and 2010 6th German Conference on Robotics (ROBOTIK)*, Munich, Germany, 7-9 June 2010, pp 1-8, ISBN 978-3-8007-3273-9.