

PROFIBUS INTERFACE BASED CONNECTION AND ACTUATION OF THE SERVO-ELECTRIC AND PNEUMATIC 2-FINGER PARALLEL GRIPPER BY USING OF THE QUICK RELEASE GRIPPER-CHANGE-SYSTEM REALIZED FOR THE FANUC ROBOT

Duško Lukač, *Department of Mechatronics*
 Rheinische Fachhochschule Köln gGmbH-University of Applied Sciences
 Vogelsanger Strasse 295, 50825 Köln, Germany
 Phone: +49-221-5468759 Fax: +49-221-5468755 E-mail: lukac@rfh-koeln.de

Abstract - The paper gives an example of the technical solution for the connection of the two different types of the 2-finger parallel gripper regarding their driving power, both used in one application process. The grippers used in the application are a servo-electric 2-finger parallel gripper with highly precise gripping force control and long stroke and a universal pneumatic 2-finger parallel gripper with large gripping force and high maximum moments. Both grippers used are connected via quick release Gripper-Change-System (GCS) and are controlled via control panel with integrated Profibus-DP master unit. The end-effector is mounted to the GCS typically by using an interface plate designed by the user. The realization of the application is specifically designed for the Fanuc robot ARC Mate 120iB and the controller R-J3iB and represents the unique technical solution, not designed with the named parts and control unit in such way before.

I. INTRODUCTION

The technical realization of the connection of the servo-electric and pneumatic 2-finger parallel gripper via quick release gripper change system for the FANUC robot ARC Mate 120iB and control unit R-J3iB [1] and in the paper described control of the system by using the Profibus-DP, is a part of the degree dissertation supervised by the author [2] aiming the construction of a robot training cell for Rheinische Fachhochschule Köln gGmbH - die University of Applied Sciences. The robot training cell serves the education of the university's students as well as the external customers who are trained at the university in the scope of the various courses offered by the university. The construction of the robot cell is presented in the Fig. 1.

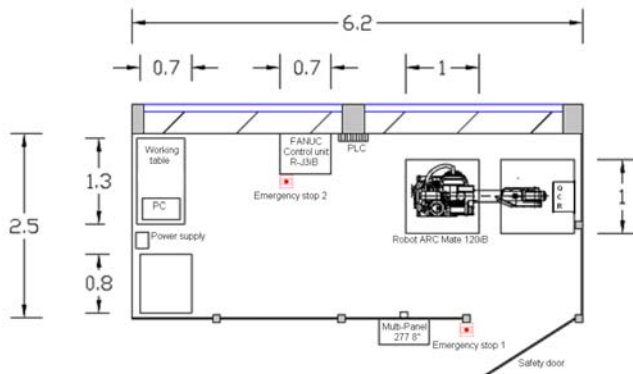

Fig. 1. Top view on the robot cell

Furthermore the solution has to fulfill the requirements of the modern industrial robot cell in order to enable the trainees to seamlessly be able to undertake the sophisticated engineering tasks in working environment.

II. DESCRIPTION OF THE SYSTEM COMPONENTS

All relevant system components used for the realization of the mentioned task are covered in greater detail below and give the reader a necessary basis for the traceability of the function of the realized system.

A. Robot system

The base of the FANUC robot system consists of three main components: robot, switch board and hand operating device. According to the DIN EN 775 standard in conjunction with DIN EN ISO 8373 the safety fence is also treated as a part of the robot system. Without the safety fence, which is designed according to the operating modes T1, T2 and automatic mode of the robot controller, robot system may not be put into operation. The control of the power engine for the robot axes is built up in the switch board. An automatic process originates from the programming of the robot movements in combination with the operating modes. The isometric view of the robot is presented in the Fig. 2.

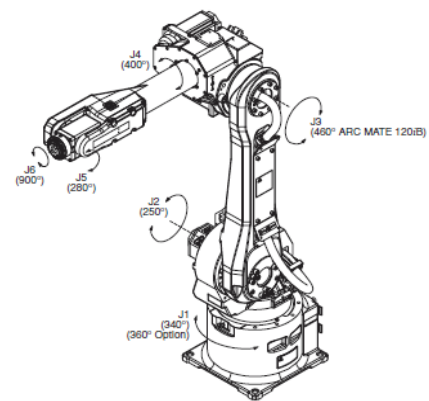

Fig.2. Isometric view of the ARC Mate 120iB

The ARC Mate 120iB series is 6 axes, electric servo-driven robot designed for precise, high-speed welding and cutting. Based on the simple and reliable construction, the ARC Mate 120iB provides accurate and consistent path performance necessary for welding and cutting. The R-J3iB controller and integrated so called Arc Tool software, provide reliable performance with high productivity. In connection with the standard VDI 2861 Part 1-3 [3] (DIN EN ISO 8373) J1 to J3 are the main axes and J4 to J6 the hand joint axes of the robot. Behind the axes-marks in the Fig.2 there are data about the robot motion range, necessary

for the determination of the workspace and the toll-workspace. The tools are mounted in the gripper flange which can be flexible integrated and exchanged according to working step. ARC Mate 120iB has 1667 mm reach and 1282 mm stroke. There are permitted 20 kg load on faceplate. In the T1-mode of operation the safety fence (safety door) figured out in Fir.1 is deactivated and the tool center point and tools flange can be moved only at a maximum speed of 250 mms/sec. In this mode the operator writes the suitable robot program and he/she can test the single robot movements and stored program sequences at low speed. In the T2-mode security fence is also inactive. A program can be started only from the operating device (robot control hand-panel) and compared with T1 mode it can be proceed with the maximum speed. The T2-mode is used to test the program with the actual tools road and the actual cycle time. In the automatic mode the function of the security fence is activated. The persons must according to the security rules, to leave robot cell. While opening the door the robot stops. By using of the operating panel placed at the robot control unit, the hand operating device or an external device, the program sequences can be started at the planned speed.

B. Electric 2-Finger Parallel Gripper PG 70

The electric 2-Finger Parallel Gripper PG 70 [4] can be used universally. It is very flexible gripper for great part range and sensitive components in clean working environments. The gripping force control is possible in the range of 30 - 200 N. Because of the adjustable force range it can be used for the sensitive gripping of accident-sensitive work-pieces. The gripper has a long stroke of 70 mm for versatile work-piece handling. The power electronics and the control unit of the gripper are fully integrated in the gripper case. It allows the creation of a decentralized control system. The gripper has a flexible actuation options for simple integration in existing servo-controlled concepts via Profibus-DP, CAN bus or RS-232. The 2-Finger Parallel Gripper PG 70 is presented in the Fig. 3.

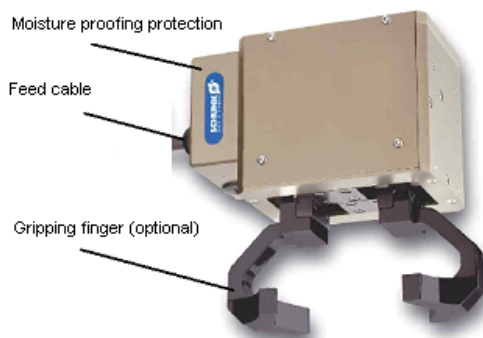

Fig.3. Electric 2-Finger Parallel Gripper PG 70

For the communication via bus-system the so called SMP - SCHUNK Motion Protocol - is used. This enables the creation of the industrial bus networks, and ensures easy integration in control systems. The gripper is actuated by brushless servo-motor (24V) who drives the ball screw by means of the gear mechanism. The rotational movement is transformed into the linear movement of the base jaw by base jaws mounted on the spindles.

The dependence of the gripping force of the finger length is presented in the following figure.

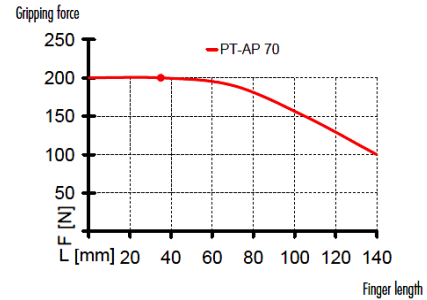

Fig.4. PG 70 gripping force in dependence of the finger length

C. Pneumatic 2-Finger Parallel Gripper PGN-plus 80

This gripper is actuated pneumatically, with filtered dry, lubricated or non-lubricated compressed air (10 μ m) [5]. Requirements on quality of the compressed air according to DIN ISO 8573-1: 644 have to be fulfilled. Working principle of the gripper is based on Wedge-hook kinematics. It is a gripper with large gripping force and high maximum moments thanks to multiple-tooth guide and it can be used universally in clean to slightly dirty environments. Because of the high maximum load capabilities gripper is suitable for the use of long gripper fingers. Air supply occurs via hose-free direct connection or screw connections for the flexible supply of compressed air in all automation systems. It allows also integration of the comprehensive sensor accessories, like e.g. MMS magnetic switches for diverse monitoring tasks and stroke position monitoring – e.g. definition of the permitted / non-permitted range. Such magnetic switch is also integrated in the realization described in this paper. The recommended work-piece weight is calculated for a force-type connection with a coefficient of friction of 0.1 and a safety factor of 2 against slippage of the work-piece on acceleration due to gravity. Considerably heavier work-piece weights are permitted with form-fit gripping. The 2-Finger Parallel Gripper PGN-plus 80 is presented in the Fig. 5.

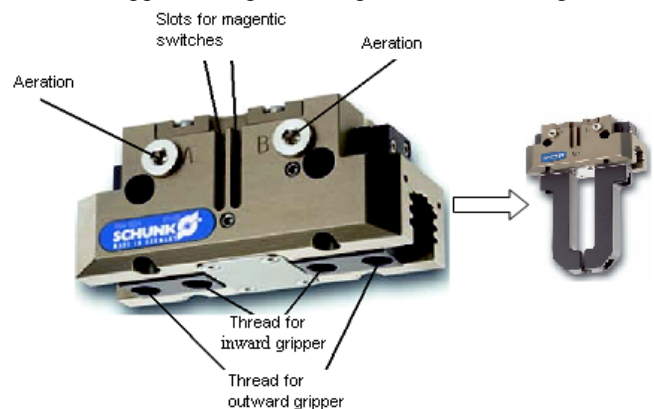

Fig.5. Pneumatic 2-Finger Parallel Gripper PGN-plus 80

The dependence of the gripping force (arithmetic total of the gripping force applied to each jaw) of the finger length is for the case of outward gripping presented in the Fig.6.

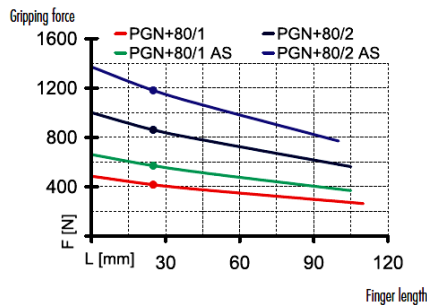

Fig. 6. PGN-plus 80 gripping force in dependence of the finger length

With nominal air pressure its closing gripping force reaches up to 415 Newton. Its maximum heave is limited to 16 mms. In order to actuate the pneumatic gripper the 3/2-direction control valve cartridges, which are equipped with throttle check valves, are used. Two 3/2-direction control valve cartridges with the nominal wide of 1.5 millimeters are actuated electrically.

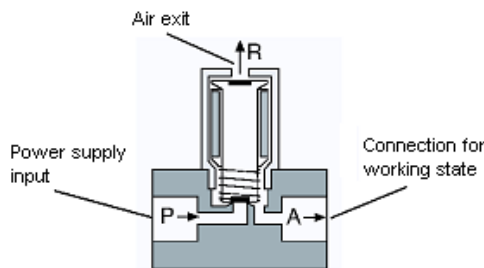

Fig. 7. 3/2-direction control valve

As figured out in the Fig. 7, in the currentless state the spring closes the power supply input P and the connection for working state A is bled via the air exit R. If the currency is switched on, the connection for working state A is connected with the power supply input P and the air exit R is closed. To influence the speed of the closing and opening of the gripper, a throttle check valve at the exit A of the 3/2-direction control valves is to be adjusted.

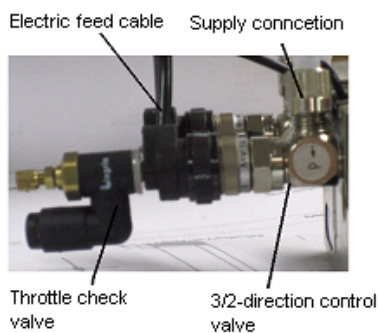

Fig. 8. Realized pneumatic actuation device

D. Electro-Pneumatic Gripper-Change-System SWS 21 and the Quick-Change Rack

Aluminum built Quick-Change-System (QCS) SWS 21 consists of a Quick-Change-Head (QCH) and a Quick-Change-Adapter (QCA) and it is used to carry out a change of the end-effectors (tools) with the different driving power, as e.g. electric and pneumatic. It builds the connection between robot flange and the gripper. The connection

assembly transmits electrical signals over the 19-pole connection pins. QCS uses patented self-retaining locking system for a safe connection between the QCS and the QCA. The QCH, mounted onto the robot, couples up the QCA mounted onto the tool. A pneumatically driven locking piston ensures that the connection is secure. After coupling, pneumatic and electric feed-throughs automatically supply the robot tool. In the event of a drop in air pressure, the locking piston is held by the cylindrical part of the locking piston. The Quick-Change-Rack (QCR) is used for to support the tools. The tools can be laid down on the QCR. The storage plate is either mounted onto the mounting block or on the 3 or 4 position adapter.

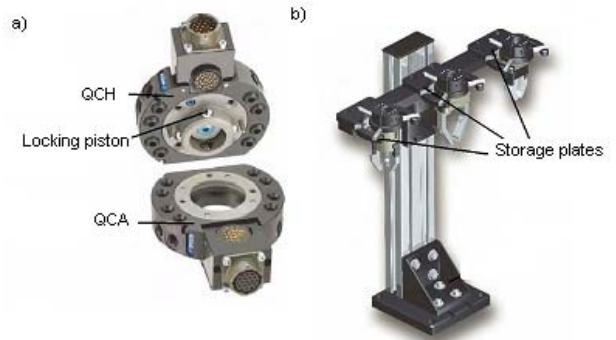

Fig. 9. a) Quick-Change-System and b) Quick-Change-Rack

In order to control the docking and undocking the QCH and QCA as well as the actuation of the air supply, so called ganged valve is used. Ganged valve consists of three 3/2-direction control valves. Laterally the baffles are fixed. The LED display shows the respective valve which is active. The wiring of the road valve cartridges lead to a 12-pole connector.

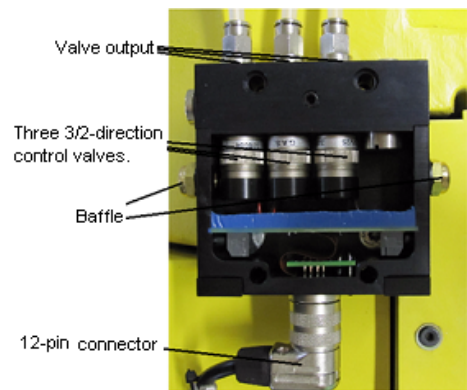

Fig. 10. Connected ganged valve

E. Operating device - Multi Panel 277 8“

For the communication between the electrical gripper and the control unit via the Profibus-DP, the new operating device Multi Panel 277 8“ (Siemens) [6] is used. It has an integrated Profibus-Master function. The handling of the panels occurs through the keys fixed in on the control panel, as presented in the Fig. 11. The respective program is presented on the TFT screen. At the side a slot for memory SD-Card is behind two USB interfaces, an Ethernet/LAN interface and RS-422 / RS-485 interface available. By using of computer with the WINAC, WIN CC flexible and Step 7 software an application program can be written and loaded in the control

panel. From there the automation process can be steered and supervised.



Fig.11. Multi Panel 277 8"(Siemens)

F. Profibus-DP Slave ET 200M

As a Profibus-DP slave system the ET200M [7] (Siemens) is used. The whole system consists of the interface module IM153-1, digital input and output component as well as of the counter component. With the interface module the single construction groups are connected and further connected up with the Profibus-Master unit. With the slip-on front connectors the construction groups can be extended. The signal construction groups are used to steer and evaluate the signal levels used. As a power supply the rectifier 24 V/5A DC is used.

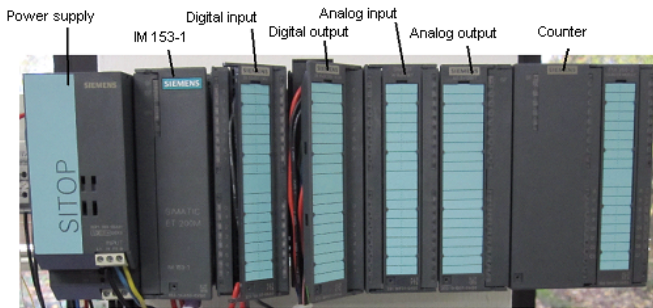

Fig.12. Profibus-DP Slave ET 200M

III. REALIZATION OF THE COMMUNICATION SYSTEM

To connect the mentioned devices presented, the communication system figured out in Fig.13 has been developed, which connects all named components. The robot is programmed by using the FANUC R-J3iB control unit, which again actuate the 2-Finger-Pneumatic-Gripper PGN plus 80 via a quick Gripper-Change-System SWS21. The 2-Finger-Electric-Gripper PG 70 is controlled via Profibus-DP which, for the intact functioning, presupposes master and slave components [8]. Therefore the electric gripper is projected for the use via control panel MP277 (Siemens) and in panel integrated visualization system [9].

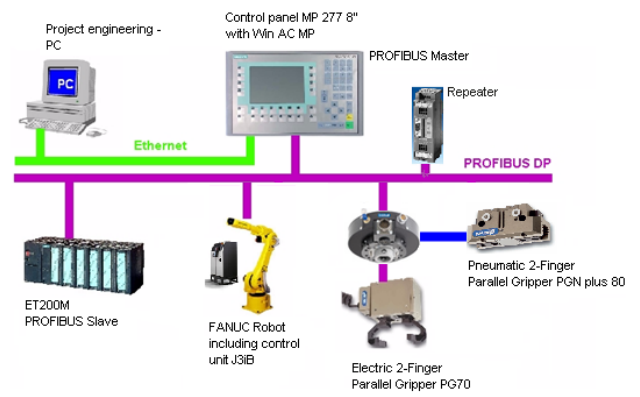

Fig.13. Communication system

The Profibus master must communicate on the other hand via the robot control unit R-J3iB with the electric gripper PG70, because the electric gripper commands are a parts of the robot program which needs to be written on the robot control unit. The commands for the robot movements are, because of the security reasons and the observance of modes of operation T1, T2 and AUTOMATIC, exclusively to be programmed via the robot control unit. In order to develop a functioning program for the control of the robot and the electric and pneumatic gripper over the control panel and robot control unit, following software components has been used: Step7 V5.4, WinCC flexible 2008 SP1 und WinAC MP 2008. These products of the Siemens company were selected because they are used very often in the German and international industry. The software Step7 is used generally to configure the hardware, for the parameterizing, to program the devices and to carry out diagnosis functions. The program WinCC flexible is visualization software which is suitable for control panels. With WinCC flexible on the basis of the projected so called "screen blocks" and graphic objects, operating and observation of the device is possible. The software-control technology WinAC MP 2008 is based on an embedded system. It concerns a combination of the hardware and software which work together as a functional unit with defined tasks. The so called Soft-PLC contained in it, which works by using of operating system Windows CE which runs on the control panel, offers a graphic user interface (GUI) for the automation tasks. As a communication interface WinAC provides a so called Softbus. The configuration of the hardware begins with the integration of the system ET200M (Profibus slave device) and the operating device MP 277 (Profibus master device). Therefore project engineering PC is used, which is connected via Ethernet with the operating device.

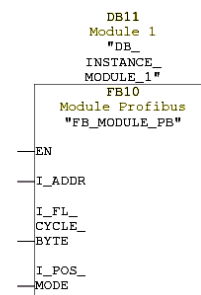

Fig.14. Cut-out of FB10

To actuate the PG70 electrical gripper, also manufacturer-specific function block, so called FB10 is

required. To parametrize the inputs of the FB10 the EEPROM data of the module PG70 are required. These data are provided by the manufacturer. In the second step the GUI of Software-PLC is loaded on the control panel. In the last step of the system configuration, the FANUC robot system and the 2-Finger-Electric-Gripper PG70 are integrated in the configuration by using of the SIMATIC manager. To integrate the FANUC robot the manufacturer-specific General Station Description (GSD) file, is required.

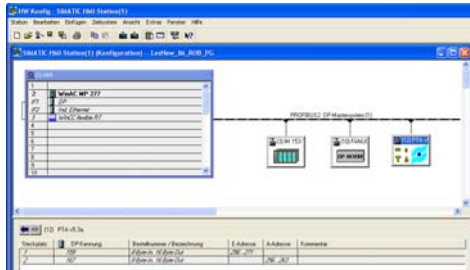

Fig. 15. Integration of the gripper in the data communication

After the system configuration, the following graphical user interface appears and can be used for the control of the electric gripper.

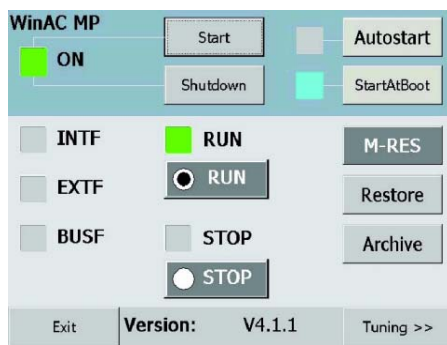

Fig. 16. Finished GUI

The realized Gripper-Change-System is presented in the following figure.

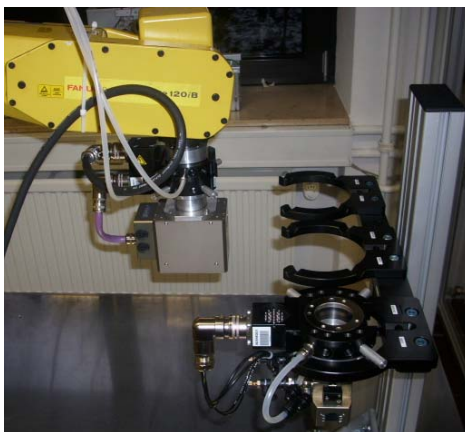

Fig. 17. Gripper-Change-System in operation

IV. CONCLUSION

Especially for the universities and other educational institutions, it is important to use equipment which enables technologically up-to-date education and the research projects in line with industrial requirements. Technical solution for the realization of the modern robot cell which is also in similar form used in the industry is presented in this paper. It can be used as a proposal for companies and universities to realize the same or similar solution.

IMPORTANT: The detailed description of the system as e.g. the configuration of the in- and outputs of the robot control unit, the setting of the tools-and base coordinate systems, complete PLC program etc. is because of the limitation of the paper length not possible. Nevertheless, this information can any time be requested from the author. Please use author's e-mail address for the request.

V. REFERENCES

- [1] FANUC, "SYSTEM R-J3iB Controller™", Available: http://www.micromech.co.uk/dir_products/pdf/fanuc/r_j3ib_controller.pdf, February 2010.
- [2] Maruszczuk, LT „Programmierung und Inbetriebnahme eines FANUC-Robotersystems mit Anknüpfung an eine Automatisierungsaufgabe (Programmierung und commissioning of a FANUC robot system and establishing of the automation process)“, December 2009, Rheinische Fachhochschule Köln gGmbH- University of Applied Sciences, pp.2-179.
- [3] VDI „Assembling and handling; characteristics of industrial robots; designation of coordinates“ Available :[http://www.vdi.de/7899.0.html?&tx_vdirili_pi2\[showUID\]=90417](http://www.vdi.de/7899.0.html?&tx_vdirili_pi2[showUID]=90417), February 2010.
- [4] Schunk “Electrical 2-Finger Parallel Gripper Universal Gripper PG70”, Available:http://www.schunk.com/schunk_files/attachments/Pg_70_En.pdf, January 2010.
- [5] Schunk “PGN-plus80 Pneumatic 2-Finger Parallel Gripper Universal Gripper”, Available: http://www.schunk.com/schunkfiles/attachments/PGN-plus_80_En.pdf, January 2010.
- [6] Siemens “Multipanel 277” Available: <http://aunz.siemens.com/NewsCentre/ProductReleases/Pages/IACPRMP277.aspx>, February 2010.
- [7] Siemens “ET200M” Available: https://www.automation.siemens.com/download/internet/cache/3/1464409/pub/de/SIP-LUS_ET200M_A2.pdf, February 2010.
- [8] Weigmann J. and Kilian G. Dezentralisieren mit PROFIBUS-DP/DPV1.Aufbau,Projektierung und Einsatz des PROFIBUS-DP mit SIMATIC S7 (Decentralize with PROFIBUS-DP/DPV1/. Construction, project engineering and application of the PROFIBUS-DP with SIMATIC S7), 3rd edn, Siemens Verlag, November 2008.
- [9] Siemens „Bedienen und Beobachten mit WinCC V6 - Modul_F05 Teil 1“ (Serve and observing with WinCC V6-module F05 part 1), Available:www.automation.siemens.com/fea/ftp/module/de/f05/f0-5wincc1.pdf,September2006,pp.2-193.